

Diamond coated end mill series for graphite

DF end mill series

High performance graphite milling.

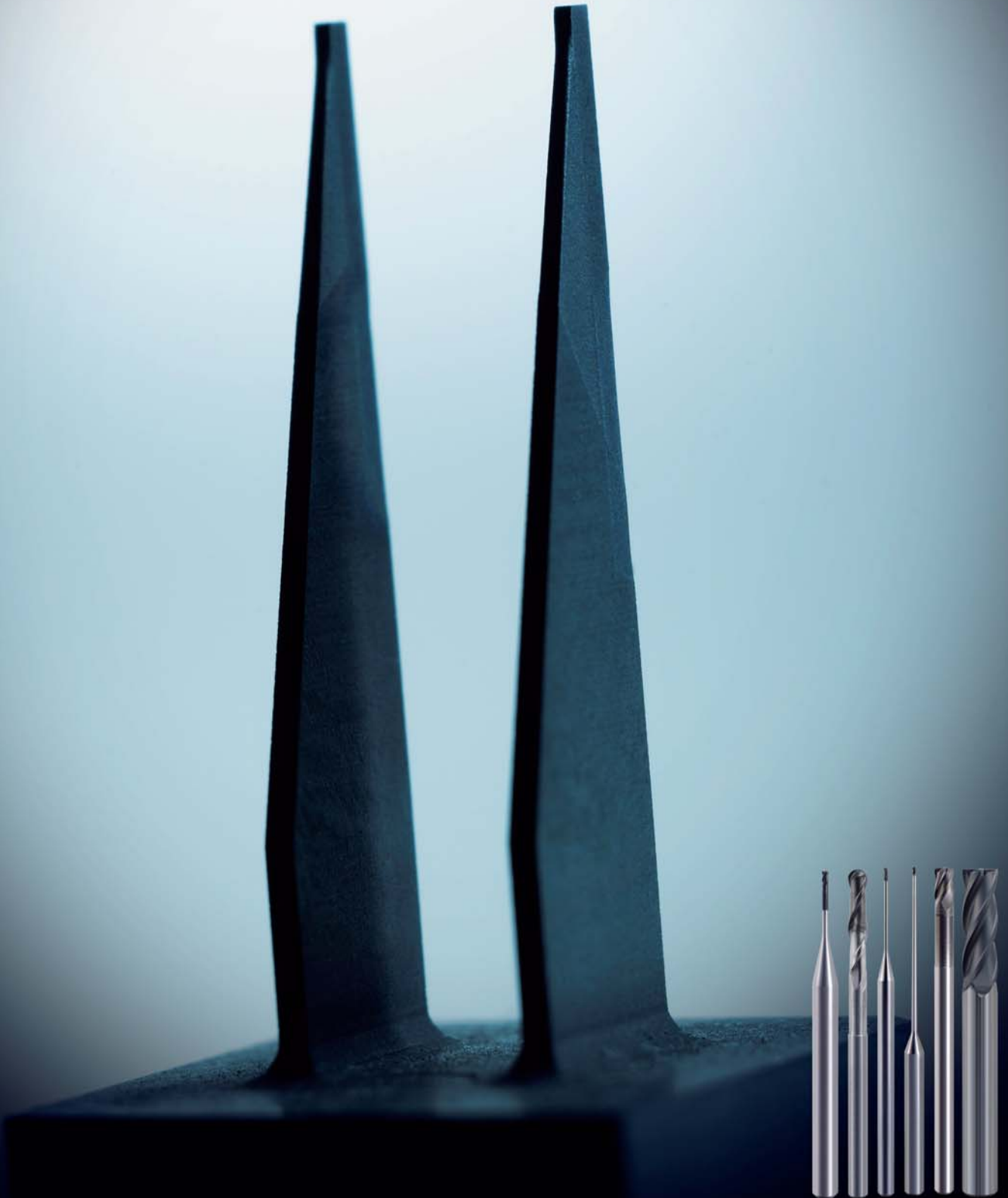

Diamond coated end mill series for graphite

DF (Diamond Four : Fixed / Fast / Fine / First) *end mill series*



Crystallized diamond coating

The diamond coating is affixed to the substrate to ensure long tool life and prevent peeling.

● Raman spectroscopy

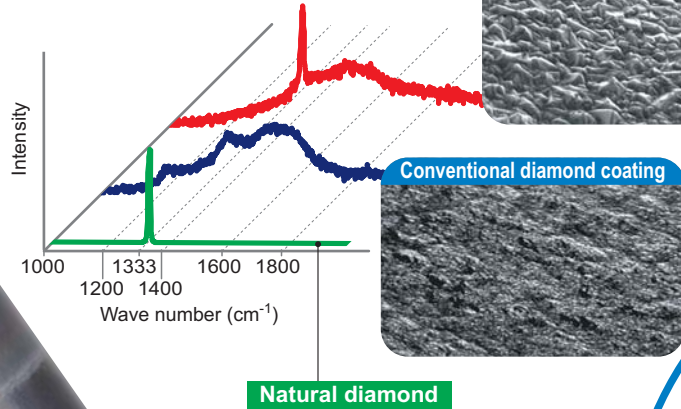

Fixed crystallized diamond structure

Fixed

Fast, long life diamond coating

Fast

● Excellent wear resistance compared to competitors end mills!

● Cutting performance (DF-4JC)

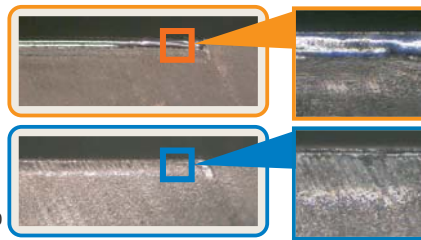
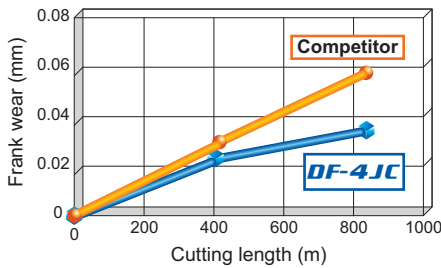

Area of photograph

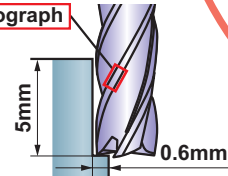

End mill	DF4JCD1200 (ø12)
Work material	Graphite (ISO-63)
Revolution	7200min ⁻¹ (271m/min)
Feed rate	2200mm/min (0.08mm/tooth)
Cutting fluid	Dry

● Cutting performance (DF-PSRB)

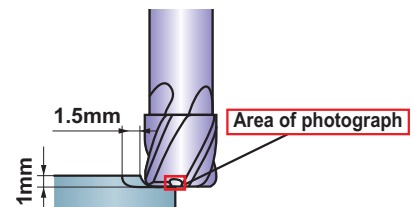
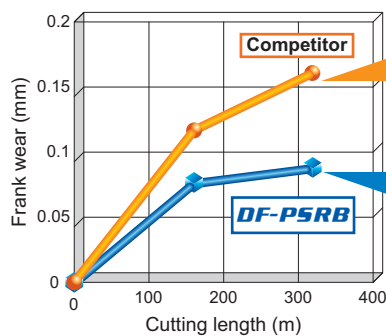

End mill	DFPSRBD0600R100N30 (ø6)
Work material	Graphite (ISO-63)
Revolution	20000min ⁻¹ (337m/min)
Feed rate	2500mm/min (0.03mm/tooth)
Cutting fluid	Dry

The seamless blend between the corner radius and peripheral cutting edge ensures a good surface finish.

DF-2MB (Seamless)

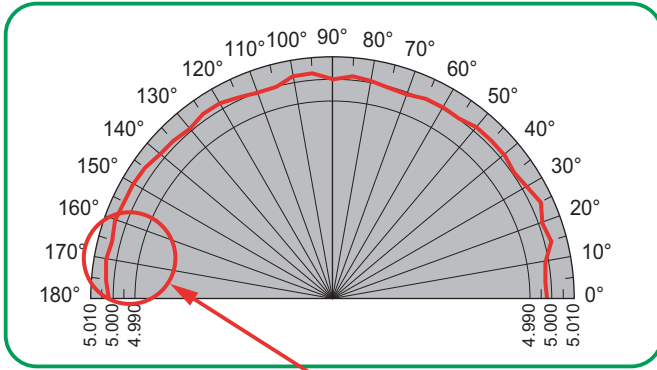

Conventional

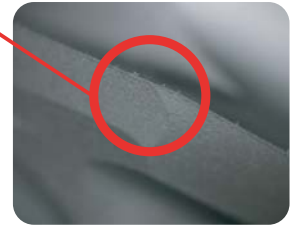
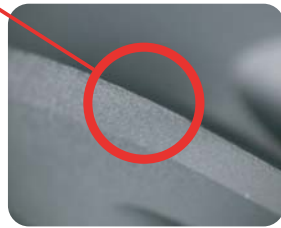
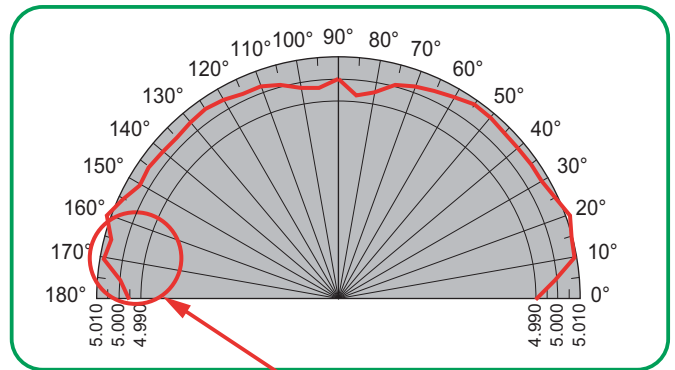

Fine seamless geometry

Fine

First

First choice for graphite machining

DF-2MB

Ball nose, Medium cut length, 2 flute,
For graphite

R3×100–R6×200mm

8 different sizes available

DF-4JC

End mill, Semi long cut length, 4 flute,
For graphite

ø3–ø12mm

6 different sizes available

DF-2XLB

Ball nose, 2 flute, Long neck, For graphite

R0.1×1–R2×60mm

42 different sizes available

DF-3XB

Ball nose, 3 flute, Taper neck, For graphite

R1×0.5×30–R2×0.5×100mm

9 different sizes available

DF-4XL

End mill, Long neck, 4 flute, For graphite

ø1×6–ø12×30mm

17 different sizes available

DF-PSRB

Corner radius end mill, Short cut length,
2-4 flute, High precision, For graphite

ø0.5×R0.1×4–ø12×R0.5×40mm

35 different sizes available



DIAMOND COATED END MILLS

DF-2XLB

Ball nose, 2 flute, Long neck, For graphite



D4=4 0 - -0.008

Aluminium Alloy	Graphite	GFRP CFRP	Machineable Ceramics
○	◎	○	○



Helix angle

Effective length
for inclined angle

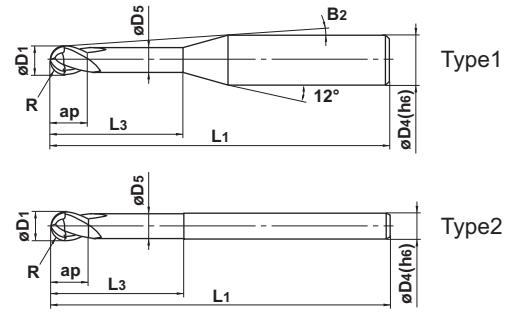
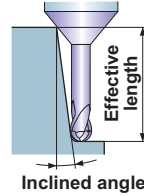

- 2 flute long neck ball nose end mill with original diamond coating for graphite machining.

Unit : mm

Order Number	Radius of Ball Nose R	Dia. D1	Length of Cut ap	Neck Length L3	Neck Dia. D5	Cutting Edge to Shank Angle B2	Overall Length L1	Shank Dia. D4	No. of Flutes N	Stock	Type	Effective length for inclined angle			
												30°	1°	2°	3°
DF2XLB R0020N010	0.2	0.4	0.6	1	0.36	11°	50	4	2	●	1	1	1	1.1	1.2
R0020N020	0.2	0.4	0.6	2	0.36	10°	50	4	2	●	1	2	2.1	2.3	2.6
R0020N030	0.2	0.4	0.6	3	0.36	9.1°	50	4	2	●	1	3.1	3.2	3.5	3.9
R0020N040	0.2	0.4	0.6	4	0.36	8.4°	60	4	2	●	1	4.1	4.3	4.7	5.2
R0020N080	0.2	0.4	0.6	8	0.36	6.4°	60	4	2	●	1	8.3	8.7	9.5	10.5
R0020N120	0.2	0.4	0.6	12	0.36	5.1°	60	4	2	●	1	12.5	13	14.3	15.8
R0025N040	0.25	0.5	0.6	4	0.46	8.3°	60	4	2	●	1	4.1	4.3	4.7	5.2
R0030N020	0.3	0.6	0.9	2	0.56	9.9°	60	4	2	●	1	2.1	2.2	2.4	2.6
R0030N040	0.3	0.6	0.9	4	0.56	8.3°	60	4	2	●	1	4.2	4.4	4.8	5.2
R0030N060	0.3	0.6	0.9	6	0.56	7.1°	60	4	2	●	1	6.3	6.5	7.1	7.9
R0030N100	0.3	0.6	0.9	10	0.56	5.5°	60	4	2	●	1	10.4	10.9	11.9	13.2
R0030N160	0.3	0.6	0.9	16	0.56	4.1°	60	4	2	●	1	16.7	17.4	19.1	21.2
R0040N060	0.4	0.8	1.2	6	0.76	7°	60	4	2	●	1	6.3	6.5	7.1	7.9
R0040N080	0.4	0.8	1.2	8	0.76	6.1°	60	4	2	●	1	8.3	8.7	9.5	10.5
R0050N040	0.5	1	1.5	4	0.94	8°	60	4	2	●	1	4.2	4.4	4.8	5.3
R0050N060	0.5	1	1.5	6	0.94	6.8°	60	4	2	●	1	6.3	6.6	7.2	8
R0050N080	0.5	1	1.5	8	0.94	5.9°	60	4	2	●	1	8.4	8.8	9.6	10.6
R0050N100	0.5	1	1.5	10	0.94	5.2°	60	4	2	●	1	10.5	11	12	13.3
R0050N120	0.5	1	1.5	12	0.94	4.6°	60	4	2	●	1	12.6	13.2	14.4	15.9
R0050N200	0.5	1	1.5	20	0.94	3.3°	80	4	2	●	1	21	21.9	24	26.6
R0050N300	0.5	1	1.5	30	0.94	2.4°	80	4	2	●	1	31.4	32.8	36	*
R0050N400	0.5	1	1.5	40	0.94	1.9°	80	4	2	●	1	41.8	43.7	*	*
R0075N080	0.75	1.5	2.3	8	1.44	5.4°	60	4	2	●	1	8.4	8.8	9.6	10.6
R0075N100	0.75	1.5	2.3	10	1.44	4.7°	60	4	2	●	1	10.5	11	12	13.2
R0075N160	0.75	1.5	2.3	16	1.44	3.4°	80	4	2	●	1	16.8	17.5	19.2	21.2
R0075N300	0.75	1.5	2.3	30	1.44	2.1°	80	4	2	●	1	31.4	32.8	35.9	*
R0100N080	1	2	3	8	1.9	4.9°	60	4	2	●	1	8.3	8.7	9.4	10.4
R0100N100	1	2	3	10	1.9	4.2°	60	4	2	●	1	10.4	10.9	11.8	13
R0100N120	1	2	3	12	1.9	3.7°	60	4	2	●	1	12.5	13	14.2	15.7
R0100N160	1	2	3	16	1.9	2.9°	80	4	2	●	1	16.7	17.4	19	*
R0100N200	1	2	3	20	1.9	2.5°	80	4	2	●	1	20.9	21.8	23.8	*
R0100N250	1	2	3	25	1.9	2°	80	4	2	●	1	26	27.2	*	*
R0100N400	1	2	3	40	1.9	1.4°	100	4	2	●	1	41.5	43.5	*	*
R0100N600	1	2	3	60	1.9	0.9°	100	4	2	●	1	62.6	*	*	*

* : No interference

Unit : mm

Order Number	Radius of Ball Nose R	Dia. D1	Length of Cut ap	Neck Length L3	Neck Dia. D5	Cutting Edge to Shank Angle B2	Overall Length L1	Shank Dia. D4	No. of Flutes N	Stock	Type	Effective length for inclined angle			
												30°	1°	2°	3°
DF2XLBR0150N160	1.5	3	4.5	16	2.9	1.7°	80	4	2	●	1	16.7	17.3	*	*
R0150N250	1.5	3	4.5	25	2.9	1.2°	80	4	2	●	1	26.1	27.2	*	*
R0150N400	1.5	3	4.5	40	2.9	0.7°	100	4	2	●	1	41.7	*	*	*
R0150N600	1.5	3	4.5	60	2.9	0.5°	100	4	2	●	1	*	*	*	*
R0200N200	2	4	6	20	3.9	—	80	4	2	●	2	*	*	*	*
R0200N300	2	4	6	30	3.9	—	80	4	2	●	2	*	*	*	*
R0200N400	2	4	6	40	3.9	—	100	4	2	●	2	*	*	*	*
R0200N600	2	4	6	60	3.9	—	100	4	2	●	2	*	*	*	*

* : No interference

DIAMOND COATED END MILLS

DF-2MB

Ball nose, Medium cut length, 2 flute, For graphite



D4 = 6 0 - -0.008
 8 ≤ D4 ≤ 10 0 - -0.009
 D4 = 12 0 - -0.011

Aluminium Alloy	Graphite	GFRP CFRP	Machineable Ceramics
○	◎	○	○

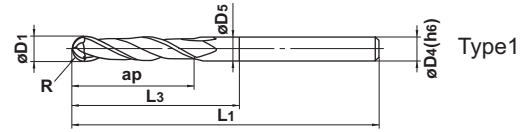

Helix angle

- 2 flute ball nose end mill with original diamond coating for graphite machining.

Unit : mm

Order Number	Radius of Ball Nose R	Dia. D1	Length of Cut ap	Neck Length L3	Neck Dia. D5	Overall Length L1	Shank Dia. D4	No. of Flutes N	Stock	Type
DF2MBR0300A100	3	6	30	50	5.85	100	6	2	●	1
R0300A150	3	6	30	50	5.85	150	6	2	●	1
R0400A110	4	8	40	60	7.85	110	8	2	●	1
R0400A150	4	8	40	60	7.85	150	8	2	●	1
R0500A120	5	10	50	70	9.7	120	10	2	●	1
R0500A180	5	10	50	70	9.7	180	10	2	●	1
R0600A130	6	12	55	75	11.7	130	12	2	●	1
R0600A200	6	12	55	75	11.7	200	12	2	●	1

DF-3XB

Ball nose, 3 flute, Taper neck, For graphite



D4=6 0 - -0.008

Aluminium Alloy	Graphite	GFRP CFRP	Machinable Ceramics
○	◎	○	○

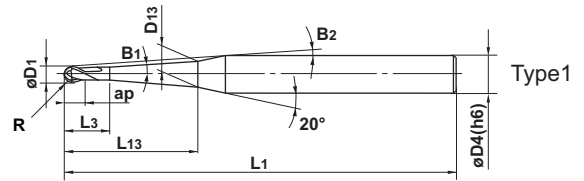

Helix angle

- 3 flute taper neck ball nose end mill with original diamond coating for graphite machining.

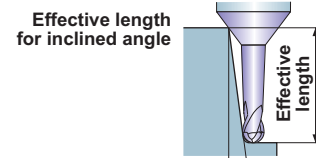

Inclined angle Unit : mm

Order Number	Radius of Ball Nose R	Dia. D1	Taper Angle One Side B1	Length of Cut ap	Neck Length L13	Length of Straight Neck L3	Cutting Edge to Shank Angle B2	Neck Dia. D13	Overall Length L1	Shank Dia. D4	No. of Flutes N	Stock	Type	Effective length for inclined angle			
														30°	1°	2°	3°
DF3XBR0050L030	0.5	1	0.5°	1.5	30	3	4°	0.94	100	6	3	●	1	30.4	32.1	32.8	34.6
R0050L040	0.5	1	0.5°	1.5	40	3	3.2°	0.94	100	6	3	●	1	40.4	41.4	43.6	46
R0050L050	0.5	1	0.5°	1.5	50	3	2.6°	0.94	100	6	3	●	1	50.4	51.7	54.4	*
R0100L040	1	2	0.5°	3	40	5	2.6°	1.9	100	6	3	●	1	40.7	41.7	43.9	*
R0100L060	1	2	0.5°	3	60	5	1.8°	1.9	130	6	3	●	1	60.7	62.2	*	*
R0100L080	1	2	0.5°	3	80	5	1.4°	1.9	130	6	3	●	1	80.7	82.7	*	*
R0150L060	1.5	3	0.5°	4.5	60	7.5	1.4°	2.9	130	6	3	●	1	60.8	62.2	*	*
R0150L080	1.5	3	0.5°	4.5	80	7.5	1.1°	2.9	130	6	3	●	1	80.8	82.8	*	*
R0200L100	2	4	0.5°	6	100	9	0.6°	3.9	160	6	3	●	1	100.8	*	*	*

* : No interference

DIAMOND COATED END MILLS

DF-4JC

End mill, Semi long cut length, 4 flute, For graphite



0 - -0.02



D4 = 6 0 - -0.008
 8 ≤ D4 ≤ 10 0 - -0.009
 D4 = 12 0 - -0.011

Aluminium Alloy	Graphite	GFRP CFRP	Machineable Ceramics
○	◎	○	○

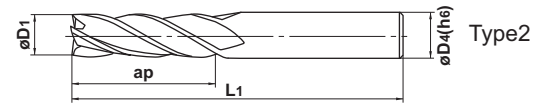
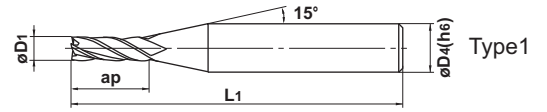

Helix angle

- 4 flute end mill with original diamond coating for graphite machining.

Unit : mm

Order Number	Dia. D1	Length of Cut ap	Overall Length L1	Shank Dia. D4	No. of Flutes N	Stock	Type
DF4JCD0300	3	12	60	6	4	●	1
D0400	4	16	60	6	4	●	1
D0600	6	24	60	6	4	●	2
D0800	8	28	70	8	4	●	2
D1000	10	35	90	10	4	●	2
D1200	12	36	110	12	4	●	2

DF-4XL

End mill, Long neck, 4 flute, For graphite



0 - -0.02



$4 \leq D_4 \leq 6$ 0 - -0.008
 $8 \leq D_4 \leq 10$ 0 - -0.009
 $D_4 = 12$ 0 - -0.011

Aluminium Alloy	Graphite	GFRP CFRP	Machinable Ceramics
○	◎	○	○

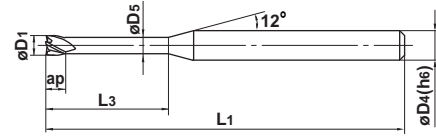

Type1

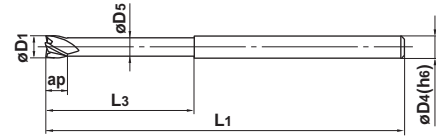

Type2



Helix angle



$D_1 < 3$



$D_1 \geq 3$

- 4 flute long neck end mill with original diamond coating for graphite machining.

Unit : mm

Order Number	Dia. D1	Length of Cut ap	Neck Length L3	Neck Dia. D5	Overall Length L1	Shank Dia. D4	No. of Flutes N	Stock	Type
DF4XLD0100N060	1	1.5	6	0.94	50	4	4	●	1
D0100N080	1	1.5	8	0.94	50	4	4	●	1
D0100N100	1	1.5	10	0.94	50	4	4	●	1
D0150N100	1.5	2.3	10	1.44	60	4	4	●	1
D0150N160	1.5	2.3	16	1.44	60	4	4	●	1
D0200N100	2	3	10	1.9	60	4	4	●	1
D0200N160	2	3	16	1.9	60	4	4	●	1
D0200N200	2	3	20	1.9	60	4	4	●	1
D0300N160	3	4.5	16	2.9	70	4	4	●	1
D0300N200	3	4.5	20	2.9	70	4	4	●	1
D0300N300	3	4.5	30	2.9	70	4	4	●	1
D0400N200	4	6	20	3.9	80	4	4	●	2
D0400N400	4	6	40	3.9	80	4	4	●	2
D0600N300	6	9	30	5.85	70	6	4	●	2
D0800N300	8	12	30	7.85	90	8	4	●	2
D1000N300	10	15	30	9.7	90	10	4	●	2
D1200N300	12	18	30	11.7	110	12	4	●	2

DIAMOND COATED END MILLS

DF-PSRB

Corner radius end mill, Short cut length, 2-4 flute, High precision, For graphite



±0.01



0 - -0.02



4 ≤ D4 ≤ 6 0 - -0.008
8 ≤ D4 ≤ 10 0 - -0.009
D4 = 12 0 - -0.011

Aluminium Alloy	Graphite	GFRP CFRP	Machinable Ceramics
○	⊙	○	○

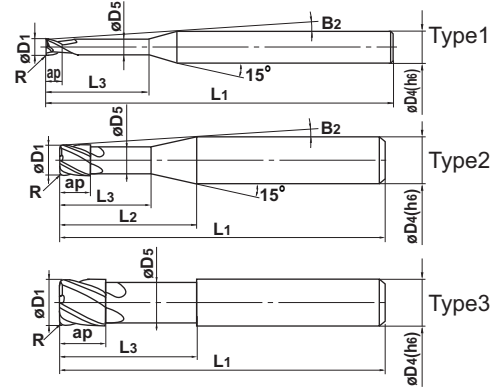

Helix angle



D1 ≤ 1.5



D1 ≥ 2

Effective length for inclined angle

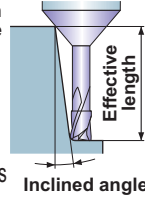

● ±0.01mm corner radius tolerance, 0 - -0.02mm outer diameter tolerance. Corner radius end mill with original diamond coating for precise and efficient graphite machining.

Unit : mm

Order Number	Dia. D1	Corner R R	Length of Cut ap	Neck Length L3	Neck Dia. D5	Cutting Edge to Shank Angle B2	Overall Length L1	Shank Dia. D4	No. of Flutes N	Stock	Type	Effective length for inclined angle			
												30°	1°	2°	3°
DFPSRBD0050R010N04	0.5	0.1	0.75	4	0.46	9.5	60	4	2	●	1	4.1	4.3	4.6	5
D0050R010N05	0.5	0.1	0.75	5	0.46	8.7	60	4	2	●	1	5.2	5.4	5.7	6.2
D0050R010N06	0.5	0.1	0.75	6	0.46	8	60	4	2	●	1	6.2	6.4	6.9	7.5
D0050R010N10	0.5	0.1	0.75	10	0.46	6.1	60	4	2	●	1	10.3	10.7	11.5	12.4
D0050R010N15	0.5	0.1	0.75	15	0.46	4.7	60	4	2	●	1	15.5	16	17.2	18.6
D0080R010N06	0.8	0.1	1	6	0.76	7.7	60	4	2	●	1	6.2	6.4	6.9	7.5
D0080R010N08	0.8	0.1	1	8	0.76	6.6	60	4	2	●	1	8.3	8.6	9.2	9.9
D0100R010N08	1	0.1	1.5	8	0.94	6.3	60	4	2	●	1	8.5	8.8	9.5	10.2
D0100R010N12	1	0.1	1.5	12	0.94	4.9	60	4	2	●	1	12.6	13.1	14.1	15.2
D0100R020N08	1	0.2	1.5	8	0.94	6.3	60	4	2	●	1	8.5	8.8	9.5	10.2
D0100R020N12	1	0.2	1.5	12	0.94	4.9	60	4	2	●	1	12.6	13.1	14.1	15.2
D0100R020N16	1	0.2	1.5	16	0.94	4	70	4	2	●	1	16.8	17.4	18.7	20.2
D0100R020N20	1	0.2	1.5	20	0.94	3.4	70	4	2	●	1	20.9	21.7	23.3	25.1
D0100R020N30	1	0.2	1.5	30	0.94	2.5	70	4	2	●	1	31.3	32.4	34.8	*
D0150R020N10	1.5	0.2	2.3	10	1.44	4.9	70	4	2	●	1	10.5	11	11.8	12.7
D0150R020N20	1.5	0.2	2.3	20	1.44	2.9	70	4	2	●	1	20.9	21.7	23.3	*
D0200R020N12	2	0.2	3	12	1.9	3.7	70	4	4	●	2	12.5	13	14	15.1
D0200R020N16	2	0.2	3	16	1.9	2.9	70	4	4	●	2	16.7	17.3	18.6	*
D0200R020N20	2	0.2	3	20	1.9	2.5	80	4	4	●	2	20.8	21.5	23.2	*
D0200R020N30	2	0.2	3	30	1.9	1.7	80	4	4	●	2	31.2	32.2	*	*
D0200R020N40	2	0.2	3	40	1.9	1.4	80	4	4	●	2	41.5	42.9	*	*
D0300R020N20	3	0.2	4.5	20	2.9	1.4	80	4	4	●	2	20.8	21.5	*	*
D0300R020N40	3	0.2	4.5	40	2.9	0.7	80	4	4	●	2	41.5	*	*	*
D0300R050N20	3	0.5	4.5	20	2.9	1.4	80	4	4	●	2	20.8	21.5	*	*
D0400R020N20	4	0.2	6	20	3.9	—	80	4	4	●	3	*	*	*	*
D0400R020N40	4	0.2	6	40	3.9	—	80	4	4	●	3	*	*	*	*
D0400R050N20	4	0.5	6	20	3.9	—	80	4	4	●	3	*	*	*	*
D0400R050N40	4	0.5	6	40	3.9	—	80	4	4	●	3	*	*	*	*
D0600R050N30	6	0.5	9	30	5.85	—	90	6	4	●	3	*	*	*	*
D0600R100N30	6	1	9	30	5.85	—	90	6	4	●	3	*	*	*	*
D0800R050N30	8	0.5	12	30	7.85	—	90	8	4	●	3	*	*	*	*
D0800R100N30	8	1	12	30	7.85	—	90	8	4	●	3	*	*	*	*
D1000R050N40	10	0.5	15	40	9.7	—	130	10	4	●	3	*	*	*	*
D1000R100N40	10	1	15	40	9.7	—	130	10	4	●	3	*	*	*	*
D1200R050N40	12	0.5	18	40	11.7	—	130	12	4	●	3	*	*	*	*

* : No interference

DIAMOND COATED END MILLS

DF-2XLB

Ball nose, 2 flute, Long neck, For graphite

Work material		Graphite			
R (mm)	Neck length (mm)	Revolution (min ⁻¹)	Feed rate (mm/min)	Depth of cut ap (mm)	Depth of cut ae (mm)
R0.2	1	40000	1500	0.05	0.15
	2	40000	1500	0.05	0.12
	3	40000	1300	0.04	0.12
	4	40000	1300	0.04	0.1
	8	30000	800	0.03	0.1
	12	20000	450	0.03	0.08
R0.25	4	40000	1500	0.05	0.15
R0.3	2	40000	1800	0.07	0.2
	4	40000	1500	0.06	0.18
	6	40000	1500	0.06	0.15
	10	35000	1000	0.05	0.15
	16	22000	530	0.04	0.12
R0.4	6	40000	1700	0.08	0.2
	8	40000	1700	0.08	0.15
R0.5	4	40000	2500	0.12	0.3
	6	40000	2500	0.1	0.3
	8	40000	2000	0.1	0.25
	10	40000	2000	0.1	0.2
	12	40000	2000	0.1	0.2
	20	30000	1100	0.08	0.2
	30	20000	600	0.06	0.15
	40	15000	400	0.04	0.12
R0.75	8	40000	2800	0.15	0.45
	10	40000	2800	0.15	0.45
	16	35000	2000	0.15	0.3
	30	27000	1000	0.1	0.3
R1	8	40000	3000	0.23	0.7
	10	40000	3000	0.2	0.6
	12	35000	2500	0.2	0.6
	16	30000	2000	0.2	0.5
	20	30000	2000	0.2	0.5
	25	25000	1500	0.18	0.45
	40	20000	1000	0.15	0.4
	60	15000	500	0.1	0.3
R1.5	16	28000	3000	0.3	0.9
	25	20000	2000	0.25	0.75
	40	16000	1500	0.2	0.6
	60	14000	1000	0.17	0.45
R2	20	21000	3300	0.5	1.5
	30	15000	2000	0.4	1.2
	40	13000	1600	0.35	1
	60	12000	1400	0.3	0.9
Depth of cut					

- 1) Cutting conditions may differ considerably due to the rigidity of the machine, or the clamping and geometry of the workpiece. Please use the above table as a standard starting point.
- 2) When high machining accuracy is needed, or the workpiece becomes chipped, we recommend lowering the feed rate.
- 3) Use a milling machine dedicated for graphite.

DIAMOND COATED END MILLS

DF-2MB

Ball nose, Medium cut length, 2 flute, For graphite

Work material		Graphite			
R (mm)	Overall length (mm)	Revolution (min ⁻¹)	Feed rate (mm/min)	Depth of cut ap (mm)	Depth of cut ae (mm)
R3	100	10000 – 16000	1200 – 2100	0.6	1.5
	150	6000 – 10000	600 – 1200	0.4	1.2
R4	110	9000 – 12000	1500 – 2200	0.8	2
	150	5000 – 9000	700 – 1500	0.6	1.6
R5	120	7500 – 10000	1700 – 2400	1	2.5
	180	5000 – 7500	1000 – 1700	0.8	2
R6	130	6000 – 8000	1300 – 1900	1.2	3
	200	4000 – 6000	800 – 1300	1	2.5
Depth of cut					

- 1) Adjust the revolution and the feed rate in range of the above table such as the overhang length.
Even so, if chattering is generated, please reduce the revolution and the feed rate proportionately.
- 2) When high machining accuracy is needed, or the workpiece becomes chipped, we recommend lowering the feed rate.
- 3) Use a milling machine dedicated for graphite.

DF-3XB

Ball nose, 3 flute, Taper neck, For graphite

Work material		Graphite			
R (mm)	Neck length (mm)	Revolution (min ⁻¹)	Feed rate (mm/min)	Depth of cut ap (mm)	Depth of cut ae (mm)
R0.5	30	20000	1100	0.05	0.13
	40	15000	750	0.04	0.11
	50	12000	500	0.03	0.1
R1	40	20000	1800	0.13	0.4
	60	15000	900	0.09	0.27
	80	12000	600	0.07	0.2
R1.5	60	14000	1700	0.15	0.45
	80	12000	1200	0.12	0.35
R2	100	10000	1100	0.2	0.5

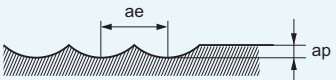
Depth of cut	
--------------	---

- 1) Cutting conditions may differ considerably due to the rigidity of the machine, or the clamping and geometry of the workpiece. Please use the above table as a standard starting point.
- 2) When high machining accuracy is needed, or the workpiece becomes chipped, we recommend lowering the feed rate.
- 3) Use a milling machine dedicated for graphite.

DIAMOND COATED END MILLS

DF-4JC

End mill, Semi long cut length, 4 flute, For graphite

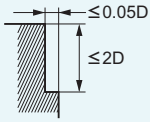
Work material	Graphite	
Dia (mm)	Revolution (min ⁻¹)	Feed rate (mm/min)
3	22000	2500
4	18000	2900
6	14000	3200
8	10500	2900
10	8700	2600
12	7200	2200
Depth of cut	 <p>The diagram shows a cross-section of an end mill cutting into a workpiece. The cutting depth is labeled as $\leq 2D$. The chip thickness is labeled as $\leq 0.05D$. The diameter of the end mill is labeled as D:Dia.</p>	

- 1) Cutting conditions may differ considerably due to the rigidity of the machine, or the clamping and geometry of the workpiece. Please use the above table as a standard starting point.
- 2) When high machining accuracy is needed, or the workpiece becomes chipped, we recommend lowering the feed rate.
- 3) Use a milling machine dedicated for graphite.

DF-4XL

Endmill, Long neck, 4 flute, For graphite

Shoulder milling

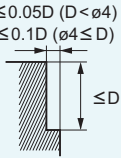
Work material		Graphite	
Dia. (mm)	Neck length (mm)	Revolution (min ⁻¹)	Feed rate (mm/min)
1	6	30000	1300
	8	25000	1000
	10	22000	700
1.5	10	25000	1200
	16	18000	800
2	10	22000	1500
	16	19000	1100
	20	16000	800
3	16	21000	1900
	20	18000	1500
	30	14000	1000
4	20	18000	2400
	40	13000	1500
6	30	14000	3200
8	30	10500	2900
10	30	8700	2600
12	30	7200	2200
Depth of cut		$\leq 0.05D$ ($D < \phi 4$) $\leq 0.1D$ ($\phi 4 \leq D$) 	

D:Dia

Slotting

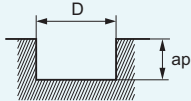
Work material		Graphite		
Dia. (mm)	Neck length (mm)	Revolution (min ⁻¹)	Feed rate (mm/min)	Depth of cut ap (mm)
1	6	30000	1000	0.1
	8	25000	700	0.08
	10	22000	500	0.06
1.5	10	25000	1100	0.14
	16	18000	600	0.1
2	10	22000	1200	0.2
	16	19000	800	0.16
	20	16000	600	0.12
3	16	21000	1400	0.3
	20	18000	1100	0.25
	30	14000	700	0.2
4	20	18000	1800	0.5
	40	13000	900	0.4
6	30	14000	2300	1.2
8	30	10500	2000	2
10	30	8700	1900	3
12	30	7200	1700	4
Depth of cut				

D:Dia

- 1) Cutting conditions may differ considerably due to the rigidity of the machine, or the clamping and geometry of the workpiece. Please use the above table as a standard starting point.
- 2) When high machining accuracy is needed, or the workpiece becomes chipped, we recommend lowering the feed rate.
- 3) Use a milling machine dedicated for graphite.

DIAMOND COATED END MILLS

DF-PSRB

Corner radius end mill, Short cut length, 2-4 flute, High precision, For graphite

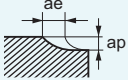
Work material			Graphite			
Dia (mm)	R (mm)	Neck length (mm)	Revolution (min ⁻¹)	Feed rate (mm/min)	Depth of cut ap (mm)	Depth of cut ae (mm)
0.5	0.1	4	30000	1100	0.05	0.23
	0.1	5	28000	960	0.05	0.23
	0.1	6	25000	850	0.05	0.23
	0.1	10	22000	600	0.04	0.21
	0.1	15	20000	500	0.03	0.18
0.8	0.1	6	28000	1300	0.08	0.45
	0.1	8	22000	900	0.08	0.45
1	0.1	8	25000	1500	0.1	0.6
	0.1	12	22000	1300	0.1	0.6
	0.2	8	25000	1500	0.1	0.45
	0.2	12	22000	1300	0.1	0.45
	0.2	16	18000	1000	0.08	0.4
	0.2	20	15000	800	0.08	0.4
	0.2	30	12000	600	0.07	0.35
1.5	0.2	10	25000	2100	0.15	0.8
	0.2	20	18000	1400	0.15	0.8
2	0.2	12	22000	3000	0.2	1.2
	0.2	16	19000	2500	0.2	1.2
	0.2	20	16000	2000	0.2	1.2
	0.2	30	13000	1600	0.16	1
	0.2	40	11000	1200	0.14	0.8
3	0.2	20	18000	3000	0.3	2
	0.2	40	12000	1800	0.25	1.7
	0.5	20	18000	3000	0.3	1.5
4	0.2	20	18000	4200	0.4	2.7
	0.2	40	13000	2800	0.4	2.7
	0.5	20	18000	4200	0.4	2.3
	0.5	40	13000	2800	0.4	2.3
6	0.5	30	14000	4600	0.6	3.8
	1	30	14000	4600	0.6	3
8	0.5	30	10500	4000	0.8	5.3
	1	30	10500	4000	0.8	4.5
10	0.5	40	8700	3500	1	6.8
	1	40	8700	3500	1	6
12	0.5	40	7200	3000	1.2	8
Depth of cut						

- 1) Cutting conditions may differ considerably due to the rigidity of the machine, or the clamping and geometry of the workpiece. Please use the above table as a standard starting point.
- 2) When high machining accuracy is needed, or the workpiece becomes chipped, we recommend lowering the feed rate.
- 3) Use a milling machine dedicated for graphite.

For Your Safety

●Don't handle tools and chips without gloves. ●Please machine within the recommended application range and exchange expired tools with new ones in advance of breakage. ●Please use safety covers and wear safety glasses. ●When using compounded cutting oils, please take fire precautions. ●When using rotating tools, please make a trial run to check run-out, vibration and abnormal sounds etc.

MITSUBISHI MATERIALS CORPORATION

MITSUBISHI MATERIALS CORPORATION Area Marketing & Operations Dept.

KFC bldg., 8F, 1-6-1, Yokoami, Sumida-ku, Tokyo 130-0015, Japan
TEL +81-3-5819-8772 FAX +81-3-5819-8774